

1500 Series 1506A-E88TAG3 ElectropaK

250 kWm standby net power @ 1500 rpm
284 kWm standby net power @ 1800 rpm

Building upon Perkins proven reputation within the power generation industry the Perkins® 1500 Series ElectropaK engines now fit even closer to our customer's needs.

The 1506A-E88TAG3 ElectropaK is a 6 cylinder, fully electronic, turbocharged, air-to-air charge cooled diesel engine. It is economical, quiet and reliable and provides the high performance that is demanded by our customers for their power generation needs.

Focusing on the Perkins common platform theme, changes to engine envelope dimensions and connection points have been kept to a minimum, making for easy installation across the ratings.

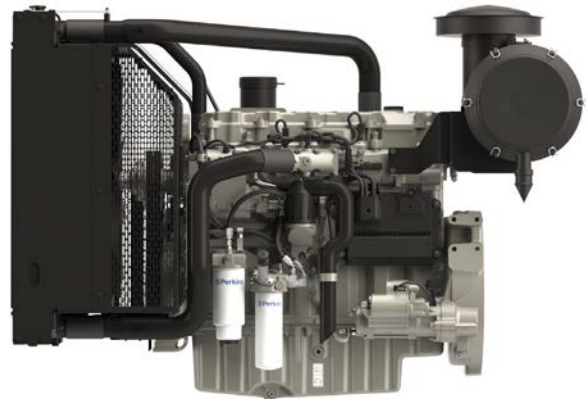

Dependable power

- The 1506A-E88TAG3 delivers greater productivity through an improved power to weight ratio.
- The world-class power density has been achieved from an 8.8 litre turbocharged engine using a hydraulic actuated unit injection (HEUI) fuel system; making this engine robust for all markets due to its ability to cope with the variation of fuel quality around the world.
- In its class, the 1506A-E88TAG3 has been designed to provide dependable power even in extreme ambient climates.

Low operating costs

- Oil change service intervals are set at 500 hours as standard.
- Designed to provide low cost of ownership, simple maintenance and reduced downtime.
- 12 months unlimited warranty with 24 months on Major items. For low use applications <500 hours per year warranty is extended by a further 12 months. See Perkins Warranty Policy for further details.
- Extended Service Contracts – protect and plan the cost of ownership.
Go to www.perkins.com/esc for more information.

Flexibility

- The 1506-E88TAG3 has been designed to hit the power node requirements of our customers.
- Switchability functionality from 50 Hz/1500 rpm to 60 Hz/1800 rpm and vice versa is available to provide greater flexibility for frequency selection.

World class product support

- Our experienced global network of distributors and dealers, fully trained engine experts deliver total service support around the clock, 365 days a year. They have a comprehensive suite of web based tools at their disposal, covering technical information, parts identification and ordering systems, all dedicated to maximising the productivity of your engine.
- Perkins actively pursues product support excellence by insisting our distribution network invest in their territory to provide customers with a consistent quality of support across the globe.
- Throughout the entire life of a Perkins engine, we provide access to genuine OE specification parts giving 100% reassurance that you receive the very best in terms of quality for lowest possible cost, wherever your Perkins powered machine is operating in the world.

To find your local distributor

www.perkins.com/distributor

Engine Speed	Type of Operation	Typical Generator Output		Engine Power Net	
		kVA	kWe	kWm	hp
1500 rpm	Prime	250	200	228	306
	Standby	275	220	250	335
1800 rpm	Prime	281	225	257	345
	Standby	313	250	284	381

1500 Series 1506A-E88TAG3 Electropak

250 kWm standby net power @ 1500 rpm
 284 kWm standby net power @ 1800 rpm

Standard Electropak specification

Air inlet system

Mounted air filter and turbocharger

Fuel system

- HEUI fuel system with full authority electronic control
- Electronic governing to ISO 8528-5 with stand-alone isochronous and load-sharing capabilities
- Fuel filter, fuel transfer pump, fuel priming pump
- Spin on primary, secondary and water filter separator

Lubrication system

- Wet full aluminium sump with filler and dipstick
- Full-flow spin-on filters
- Oil pump, gear driven

Cooling system

- Thermostatically controlled with belt driven, circulating pump and belt-drive fan
- Mounted belt driven pusher fan
- Radiator supplied loose with all guards and pipes
- Air-to-air charge cooler incorporated in radiator

Electrical equipment

- 24V starter motor and 24V, 45 amp alternator with DC output
- Electronic Control Module (ECM) mounted on engine with wiring looms and sensors

Flywheel and housing

- High inertia flywheel to SAE 1 J620 Size 355.6 mm (14 in)
- Aluminium SAE 1 flywheel housing

Mountings

Front engine mounting bracket

Engine data

Number of cylinders Vertical in-line 6 cylinder
 Bore and stroke..... 112 x 149 mm (4.5 x 5.8 in)
 Displacement 8.8 litres (537 cubic in)
 Aspiration Turbocharged aftercooled
 Cycle.....4 stroke
 Combustion system..... Direct injection
 Compression ratio 16.1:1
 Engine rotationAnti-clockwise viewed on flywheel
 Cooling system.....Liquid
 Total lubrication capacity..... 41 litres (9.01 US gal)

Dimensions:

Length including air cleaner.....1941 mm (76 in)
 Width.....1013 mm (40 in)
 Height.....1366 mm (54 in)

Dry weight 1136 kg (2502 lb)

Final weight and dimensions will depend on completed specification

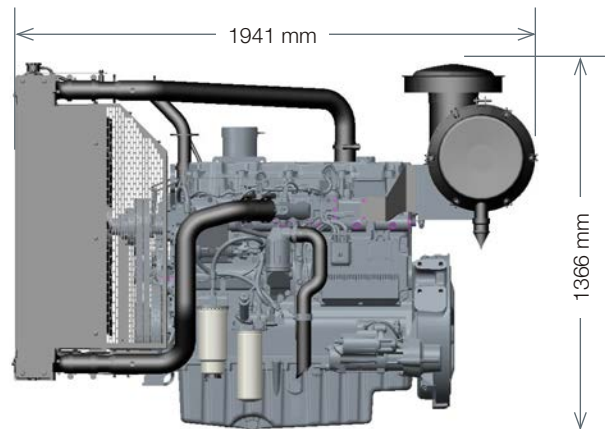

Fuel Consumption litres/hour				
Engine Speed	1500 rpm		1800 rpm	
	g/kWh	l/hr	g/kWh	l/hr
Standby	200	61	200	70
Prime Power	199	56	199	63
75% of Prime Power	199	42	199	48
50% of Prime Power	208	29	208	33

Perkins Engines Company Limited

Photographs are for illustrative purposes only and may not reflect final specification.

All information in this document is substantially correct at time of printing and may be altered subsequently.
 Publication No.PN3088/12/14 Produced in England ©2014
 Perkins Engines Company Limited



DAI LIENG TRADING SDN BHD (223694-K)
 Lot 2541, Jalan Manettia, Piasau Lorong 8,
 Pujut-Lutong Road, P.O.Box 1337,
 98000 Miri, Sarawak, Malaysia.
 Tel: +60 85 655855 Fax: +60 85 655618
 Email : headoffice@dailieng.com.my
 Website : www.dailieng.com.my



THE HEART OF EVERY GREAT MACHINE