

Hiab Multilift XP Classic range hooklifts



Basic Data

XP18T

Technical data

Type

XP18T

Vehicle type	3 axle	
GVW of the vehicle (t)	26	
Capacity (t)	18	
G-length	46	51
System weight (kg) *	1780	1880
Tipping angle (°)	50	49
Max. operating pressure (MPa)	30	
Recommended max. oil flow (l/min)	80	

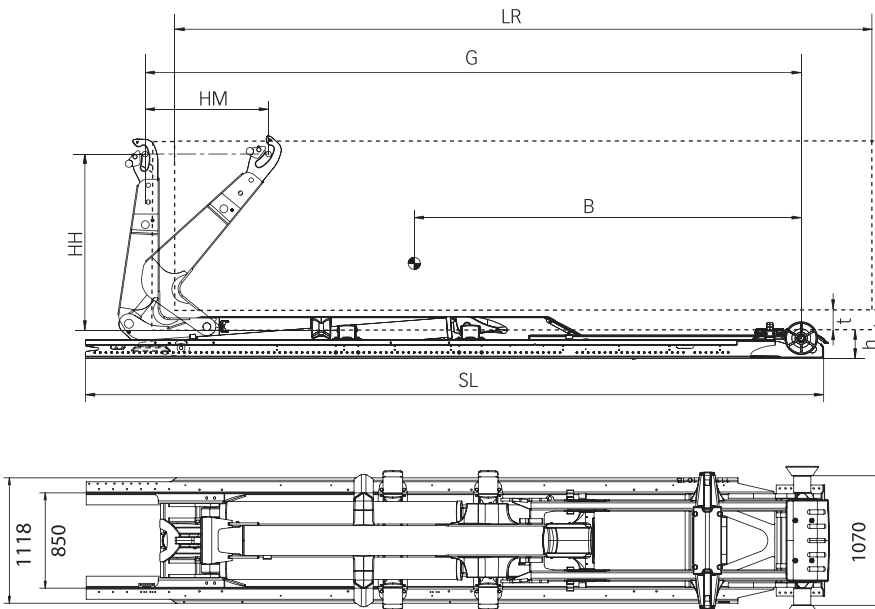

* Weight includes hydraulic body locking and excludes oil tank and oil.

** The subframe length (SL) can be reduced to achieve a final installation length. The minimum installation length depends upon country and control valve position. For an exact installation length dimension please contact your local Hiab Multilift dealer.

*** Other hook heights for different body standards available.

Hiab Multilift equipments meet the demands set forth in the EU Machine Directive and they can be CE marked. We reserve the rights for modifications. Illustrations do not always show an equipment in standard version.

Primary dimensions

Model	XP18T.46	XP18T.51
LR = Body length (m) (min – max)	3.8 - 5.6	4.3 - 6.1
SL = Subframe length (mm) **	5308	5758
B = Centre of gravity (mm)	2550	2800
G = Exact G-length (mm)	4580	5080
HM = Horizontal movement (mm)	1100	1100
t = Min free tunnel height (body) (mm)	125	
h = Installation height (mm)	230	
HH = Hook height (mm) ***	1570	

Cargotec improves the efficiency of cargo flows on land and at sea - wherever cargo is on the move. Cargotec's brands MacGregor, Kalmar and Hiab are recognised leaders in cargo and load handling solutions around the world. Cargotec's global network is positioned close to customers and offers extensive services that ensure the continuous, reliable and sustainable performance of equipment. www.cargotec.com



DAI LIENG TRADING SDN BHD (223694-K)
 Lot 2541, Jalan Manettia, Piasau Lorong 8,
 Pujut-Lutong Road, P.O.Box 1337,
 98000 Miri, Sarawak, Malaysia.
 Tel: +60 85 655855 Fax: +60 85 655618
 Email : headoffice@dailieng.com.my
 Website : www.dailieng.com.my