

HIAB X-CL 12



HIAB X-CL 12 TECHNICAL DATA

Technical data	12-1	12-2	12-3
Max. lifting capacity (kNm)	109	104	102
Lifting capacity (tm)	11.1	10.6	10.3
Outreach / lifting capacity, hydraulic extension (m/kg)	2.3 / 4700 4.2 / 2640 5.8 / 1920 - -	2.8 / 3800 4.2 / 2520 5.8 / 1800 7.6 / 1360 -	3.1 / 3350 4.3 / 2380 5.9 / 1680 7.7 / 1240 9.4 / 1000
Outreach / lifting capacity, manual extension (m/kg)	7.7 / 1380 9.6 / 1040	9.5 / 1020 -	- -
Outreach, hydraulic extensions (m)	6.0	7.9	9.8
Hydraulic boom extensions (m)	1.8	3.5	5.3
Outreach, manual extensions (m)	9.8	9.8	
Lifting height above installation level (m)	-	-	-
Recommended oil flow (l/min)	30	30	30
Power needed at rec. oil flow (kW)	18.5	18.5	18.5
Max. working pressure (MPa)	30.5	30.5	30.5
Tank Capacity (l)	40	40	40
Slewing angle (°)	406	406	406
Max. slope viable at full capacity (°)	5	5	5
Slewing torque, gross (kNm)	14.1	14.1	14.1
Slewing speed (°/s)	15	15	15
Lifting speed at standard hydraulic outreach (m/s)	0.8	1.1	1.3
Height in folded position (mm)	2170	2170	2170
Width in folded position (mm)	2430* / 2490**	2430* / 2490**	2430* / 2490**
Installation space needed (mm)	685	745	745
Weight, standard version (kg)	1100	1220	1330
Frame attachments (kg)	13 - 39	13 - 39	13 - 39
Weight, stabilizer equipment (kg)	75 - 98	75 - 98	75 - 98

*Fixed stabilizers

**Titable stabilizers

HIAB X-CL 12-1

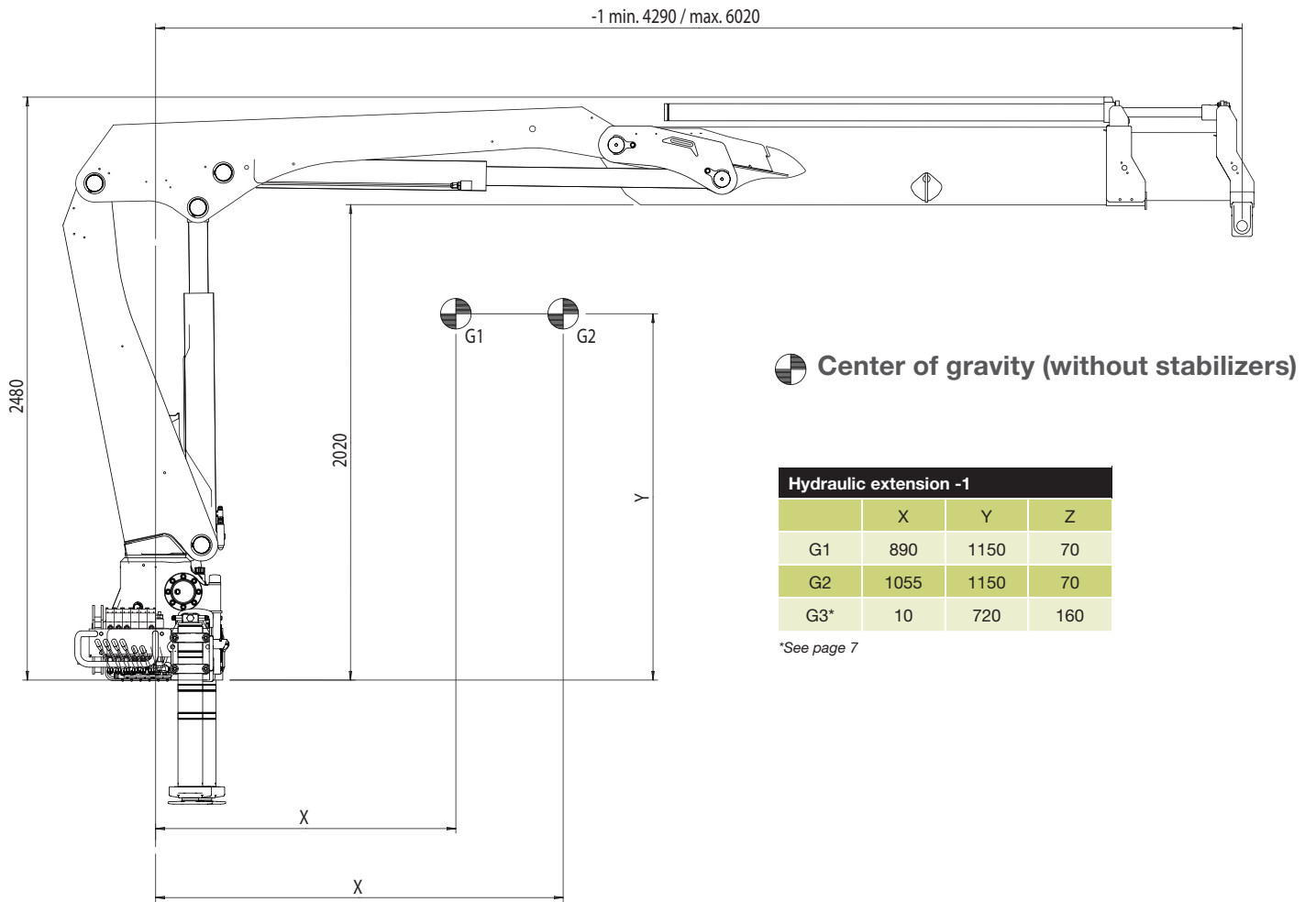

Load diagram

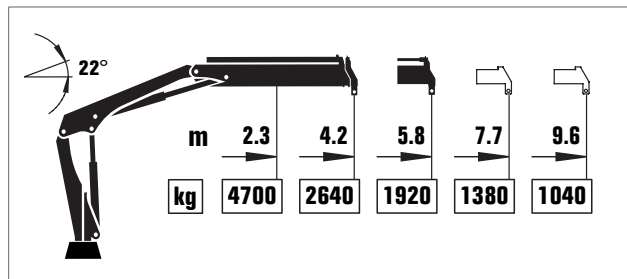
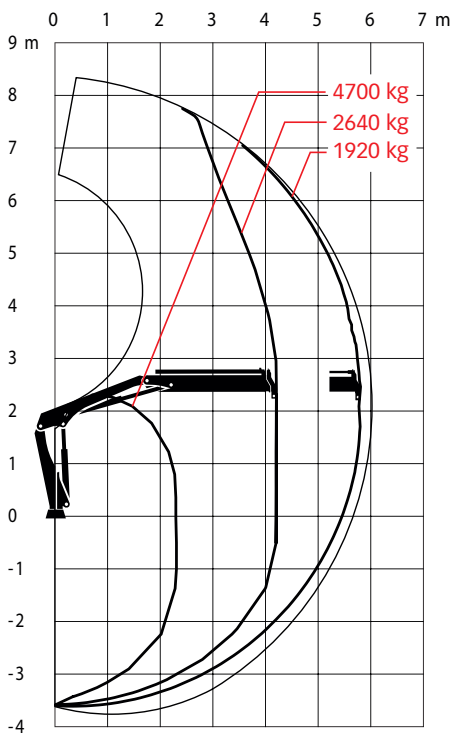

HIAB X-CL 12-2

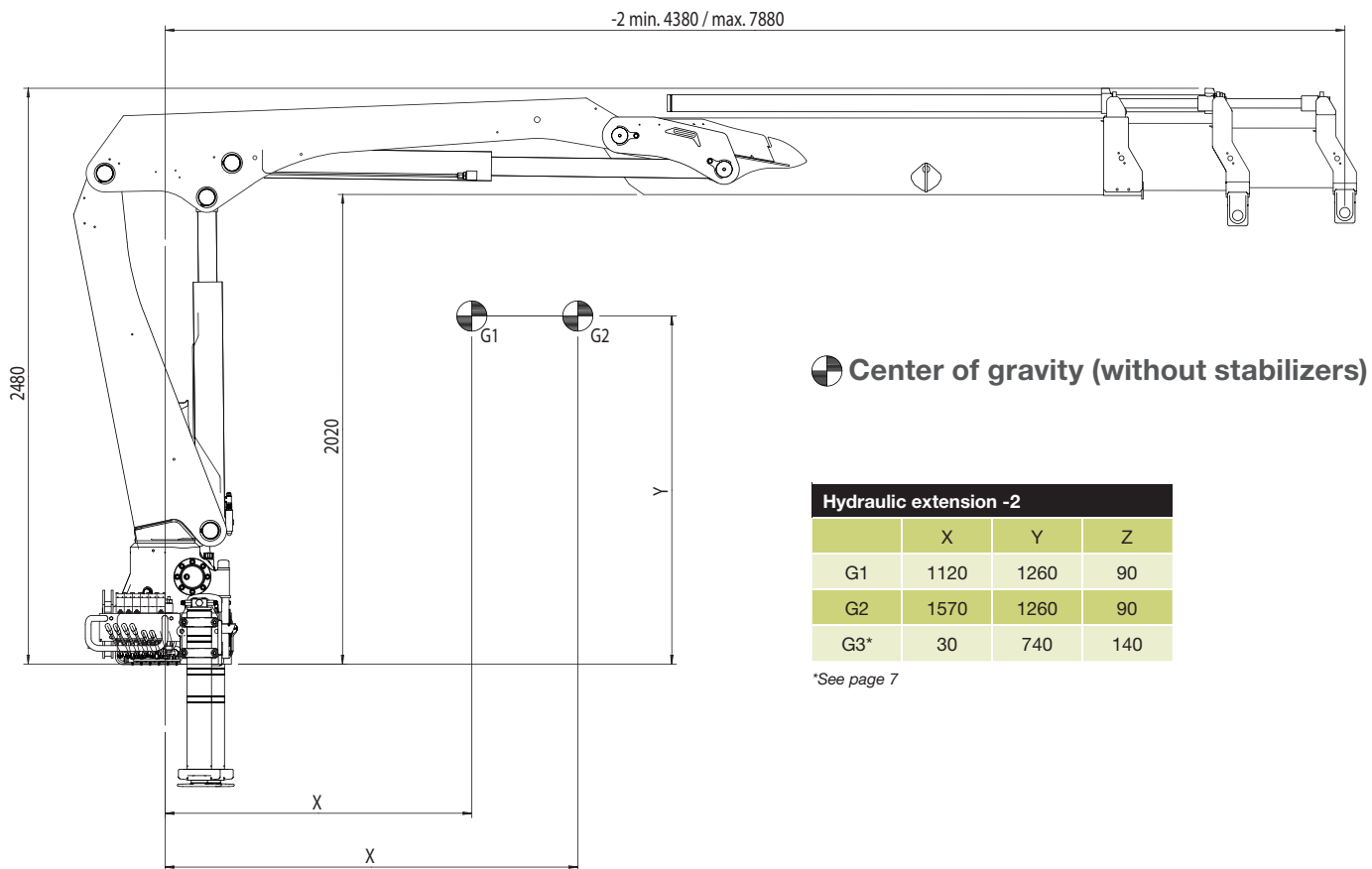

Load diagram

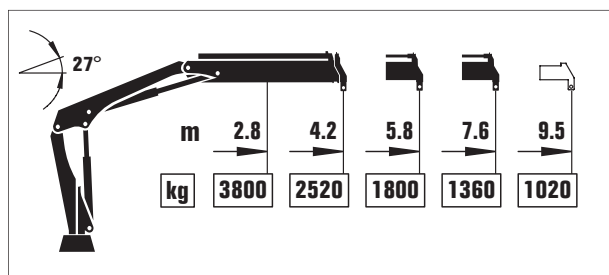
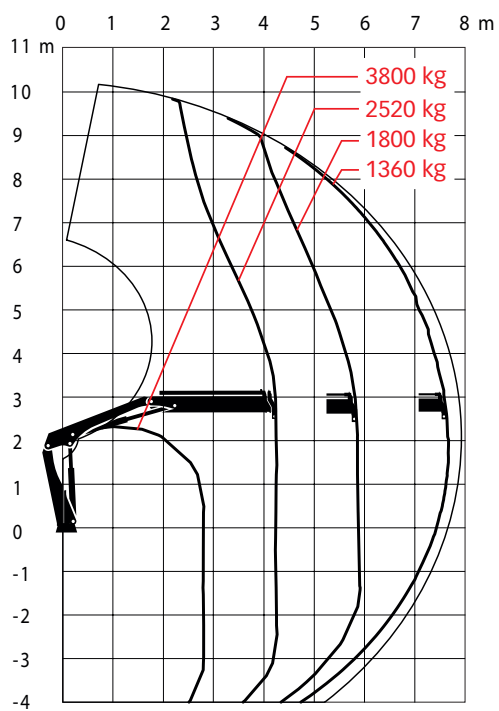

HIAB X-CL 12-3

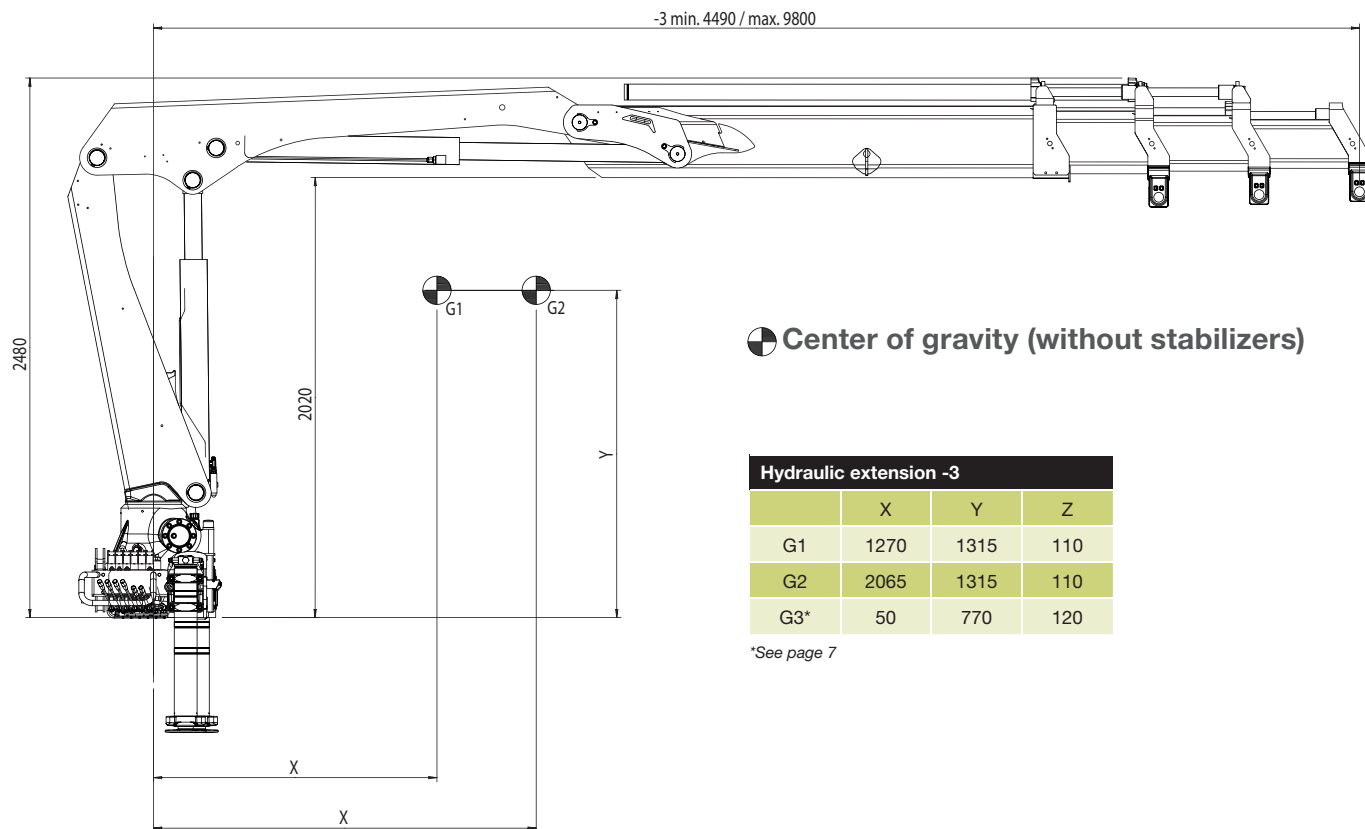

Load diagram

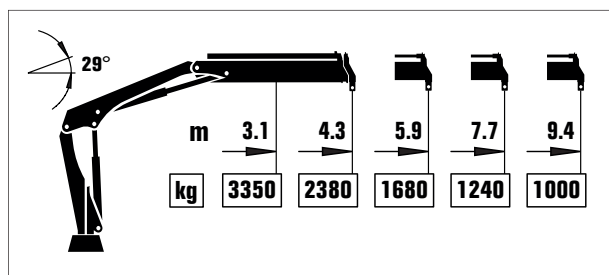
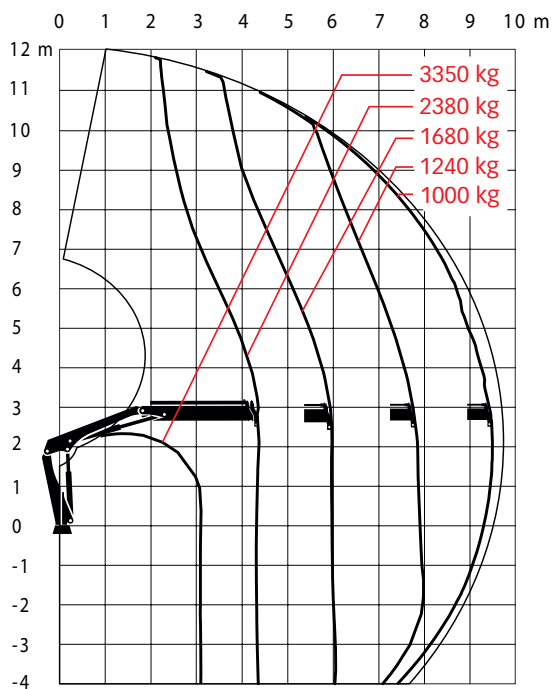

HIAB X-CL 12

Hydraulic extension	-1	-2	-3
2-1	2248	2183	2127
2-2	2540	2438	2352

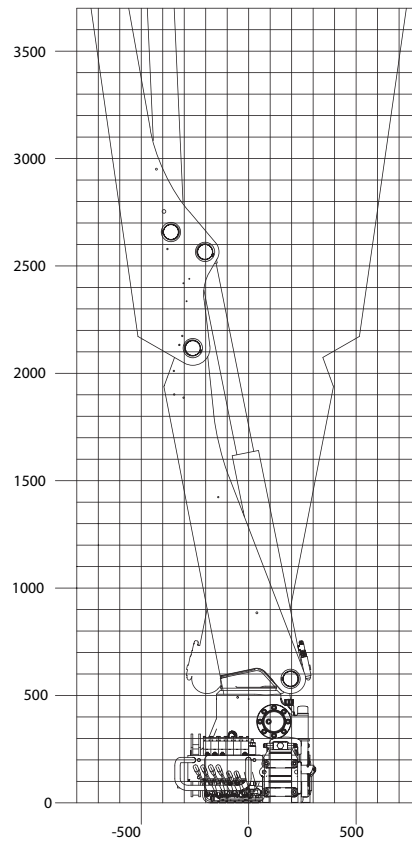
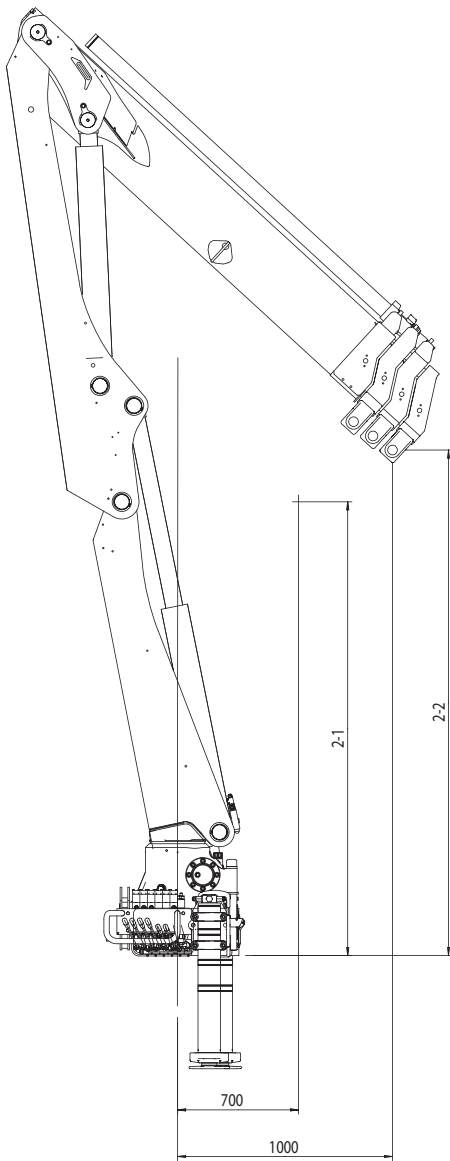

HIAB X-CL 12

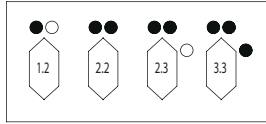

Hydraulic extension	1.2	2.2	2.3	3.3
4-1	685	685	745	745

Base	2500		
	Manual outrigger legs	Tilttable outrigger legs	
3-4	2130	2190	
3-5a/b	1215	1245	
3-7a/b	1835	1865	S
	2485	2515	M
	2755	2785	L
5-5a/b	1120	1180	

Centre of gravity	X	Y	Z
	G1, hydraulic extension -1	890	1150
G1, hydraulic extension -2	1120	1260	90
G1, hydraulic extension -3	1270	1315	110
G2, hydraulic extension -1	1055	1150	70
G2, hydraulic extension -2	1570	1260	90
G2, hydraulic extension -3	2065	1315	110
G3, hydraulic extension -1	10	720	160
G3, hydraulic extension -2	30	740	140
G3, hydraulic extension -3	50	770	120

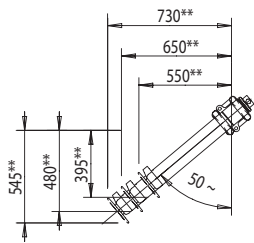
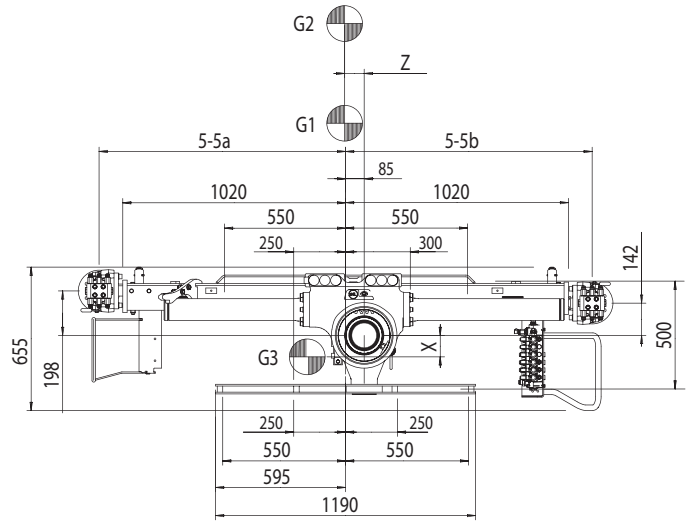
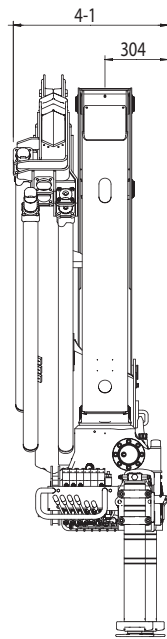

** Choice of support leg lengths

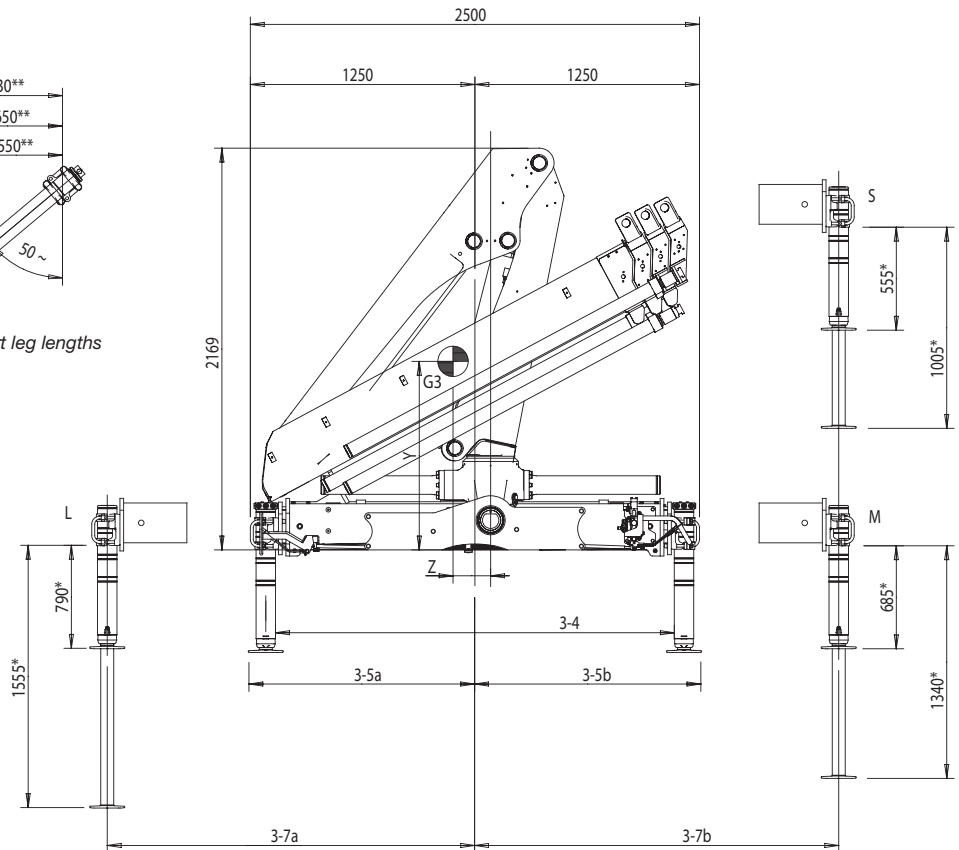

* Depends on mounting position

THE LOAD HANDLING SPECIALISTS

Hiab is the world's leading provider of on-road load handling equipment. Customer satisfaction is the first priority for us. Hiab's product range includes HIAB loader cranes, JONSERED recycling and forestry cranes, LOGLIFT forestry cranes, MOFFETT truck-mounted forklifts and MULTILIFT demountables, as well as DEL, WALTCO and ZEPRO tail lifts. www.hiab.com

Hiab is part of Cargotec. www.cargotec.com



TD-XCL12-EN-EU_140408



hiab.com



DAI LIENG TRADING SDN BHD (223694-K)

Lot 2541, Jalan Manettia, Piasau Lorong 8,
Pujut-Lutong Road, P.O.Box 1337,
98000 Miri, Sarawak, Malaysia.

Tel: +60 85 655855 Fax: +60 85 655618

Email : headoffice@dailieng.com.my

Website : www.dailieng.com.my