



HIAB

JG 2.8 GRABBER

For Infield Collection



Application Brochure

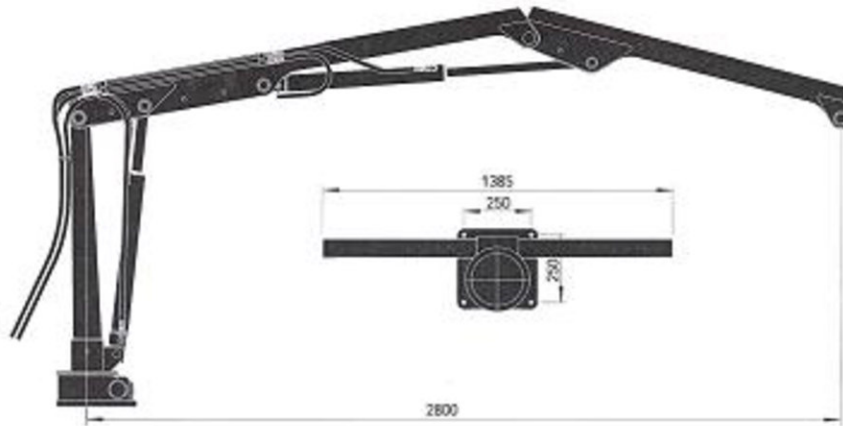

- Computer aided design and robot welded high tensile steel means lowest weight and highest quality.
- Lifetime fatigue tested in HIAB's advanced test laboratories.
- Integrated hydraulic shock absorber system to ensure long lifetime.
- High speed hydraulic system of low pressure type (90bar) for longer service life and reduced maintenance costs.
- Hydraulic buffer system in outer boom cylinder to improve durability.
- HIAB *JET GRABBER 2.8* covers a 5.6m working area.
- Heavy duty rack and pinion rotating system.

QUALITY SYSTEM

 CERTIFIED ACCORDING
 TO
 DS/ISO 9001 (DS/EN 29001)

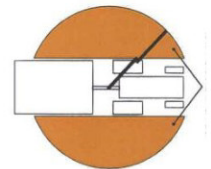

Technical Data

Description		Specification	Remarks
Lifting Capacity		0.4 ton - m	
Max. Working Radius		2.8m	
Outreach-Lifting Capacity		1.0m / 400kg	
		2.0m / 200kg	
		2.8m / 145kg	
Working Pressure		90 kg/cm ³	(9 Mpa)
Rated Oil Flow		12 l/min	
Lifting	Speed	7 sec	
	Angle	'-50° ~ 51°	
Slewing	Angle	330°	
	Speed	45° / sec	
	Type	Single rack gear	
Weight c/w Grabber		210kg	

JG5000 LOAD DIAGRAM

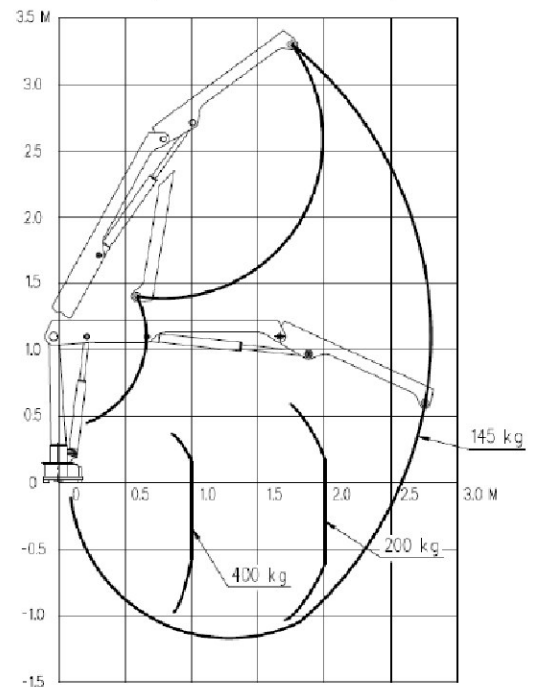

NOTE! Specifications are subject to change without prior notice. Also note that some items that appear in this brochure may be optional, and some applications may require the approval of local authorities.



The World's No.1 Selling Articulated Crane
 HIAB is a Cargotec Company



DAI LIENG TRADING SDN BHD (223694-K)
 Lot 2541, Jalan Manettia, Piasau Lorong 8,
 Pujut-Lutong Road, P.O. Box 1337,
 98008 Miri, Sarawak, Malaysia
 Tel: 085-655855 (6 lines) Fax: 085-655618
 E-mail : info@dailieng.com.my
 Website: www.dailieng.com.my