

BUFFALO

Multifunction Agricultural Tractor

Fully Imported From Italy



Machine Weight: 780kg

Max. loading
capacity: 900kg

11.3HP Yanmar
Diesel Engine

5 Speeds + 1 RV

Central Articulation +/-15°

Floatation Tyres

Specialize for tropical crops mainly,
oil palm, cocoa, rubber, palm hearth,
huachai and more.

4X4 Traction



MULTI FUNCTION AGRICULTURAL BUFFALO TRACTOR

Constructed Essentially for Hauling, Spraying & Spreading when fixed with interchangeable attachments in connection with the main use of the tractor.

Dump Bucket



Scissor-lift

Fertilizer Spreader



Attachment: Chemical Sprayer

Engine

Yanmar Diesel L100N 435cc 1 cylinder.
11.3 Hp (kW 8.3), dry air-filter, fuel water trap, electric starter, battery 50Ah, dry clutch single plate.
EU Emission Compliant.

Power Take Off

Variable Speed dependent from gearbox.
PTO on/off mechanism and lever to drive implements/accessories such as Spreader, Sprayer

Steering

Rack and pinion. Lock to lock 2 ¼ turns.
Hydraulic steering on request

Chassis

Central oscillating pivot +/-15° each side for optimization of 4x4 traction.

Transmission

Synchromesh Gearbox 5 speeds +1 Rv.
Available high/low range.
1a 2a 3a 4a 5a Rv.
Std 4.4 - 8.5 - 12.7 - 16.6 - 20.6 - 7.7
Hi 6.2 - 12 - 17.9 - 23.4 - 29.1 - 6.6
Lo 2.4 - 4.2 - 6.2 - 8.1 - 10.1 - 2.

Suspension

Silent Block Hybrid System:
4 per front wheels and 6 per wheels.

Wheels

29 - 12.5x15 4PR High Floatation
(10 psi at ground).

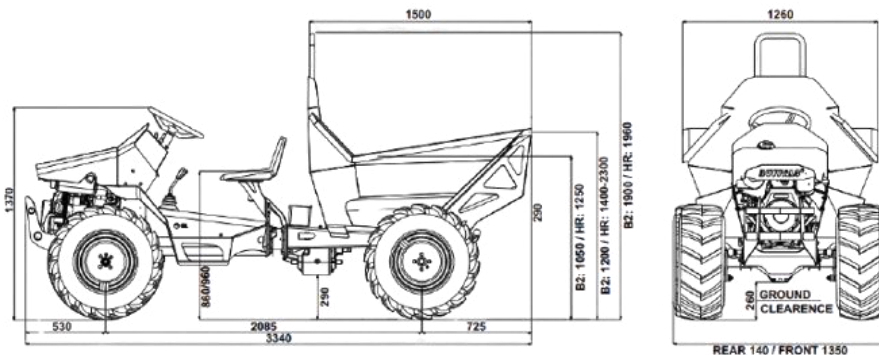

Total length: 3340mm
Wheelbase: 2085mm
Ground clearance: 260mm
Empty weight: 780kg
Max. Payload: 900kg
Min. Turning Radius: 4500mm



DAI LIENG TRADING SDN BHD (223694-K)
Lot 2541, Jalan Manettia, Piasau Lorong 8,
Pujut-Lutung Road, P.O. Box 1337,
98008 Miri, Sarawak, Malaysia
Tel: 085-655855 (6 lines) Fax: 085-655618
E-mail : info@dailieng.com.my
Website: www.dailieng.com.my

